

Items in genealogy files of Ann Arnold Hennings

Copy of Eugene Scheel's "An Archaeological Reconnaissance and Historic-Site Survey of the Broad Run Church, Graveyard, and Environs at Broadlands, Near Ashburn, Loudoun County, Virginia" – dated April-May 1995. No photographs and map are attached. Copy submitted by Scheel to Thomas Balch Library in 1995.

Robert Stoy 10 Nov 2020

BROADLANDS ASSOCIATES

11911 FREEDOM DRIVE, SUITE 300
RESTON, VIRGINIA 22090
TELEPHONE (703) 742-6400
FAX: (703) 742-6447

April 25, 1997

Ms. Ann Hennings
5100 Dorset Avenue
Apt. 206
Chevy Chase, MD 20815

Dear Ann,

Here is the historical research done on the cemetery and stone house at Broadlands. It's very interesting and I hope it helps with your research into your "roots." Please give John Lewis a call, he said he'd be more than happy to show around the property and answer any questions. If you need anything else please don't hesitate to call me.

Sincerely,



Kimberly Nestor Ambrose
Director, Marketing

An Archaeological Reconnaissance and Historic-Site Survey

Of The Broad Run Church, Graveyard, and Environs

At Broadlands, Near Ashburn

Loudoun County, Virginia

Prepared for Mobil Land Development (VA) Corporation

By Eugene M. Scheel

April - May, 1995

Route 1, Box 260

Waterford, Virginia 22190

703 / 882-3428

Eugene M. Scheel

May 4, 1995

Route 1, Box 260
Waterford, Virginia 22190
703 / 882-3428

Mr. David R. Schultz, General Counsel
Mobil Land Development (VA) Corporation
11911 Freedom Drive, Suite 300
Reston, Virginia 22090-5604

Dear Mr. Schultz;

There are three main purposes of this Draft Study: 1) To define the boundaries of the Broad Run Church property, which held a church and graveyard; 2) To ascertain who might be buried in the graveyard, as the amount and dates of interments could determine the size and shape of the graveyard; 3) To find out from long-time residents and persons with kin in the graveyard how they would like to see the graveyard and church lot maintained, beautified, fenced, etc. As a land-use planner familiar with historic preservation, I have added my thoughts to the last item.

As a corollary to the above three points, I have garnered other information: where the church stood, something about persons interred, information regarding the stone house--related to the graveyard and church tract--an miscellaneous historical data. Sources and notes follow the main text, and an accompanying map notes the various boundaries and other related information.

All persons whom I spoke with in regard to this Draft Study were pleased that the Mobil Land Development Corporation was interested in preserving the graveyard, and many felt remiss in that they had let it 'go down hill.'

I enjoyed preparing the study. Please let me know if I can be of further assistance.

Sincerely,

Eugene M. Scheel (Gene)

Eugene M. Scheel

Contents

p. 1	Letter of Transmittal
p. 2	Contents
p. 3	Methodology
p. 4	A Helpful Hint To Reading This Draft Study
p. 5	Suggestions
p. 7	History of the Broad Run Church Property
p. 9	Summary of The History
p. 11	The Graveyard
p. 21	The Stone House
p. 22	The Schoolhouse Lot
p. 23	References
p. 26	References and Notes to Map
p. 27	References to On-Site Visits and Phone Conversations
p. 28	References to Correspondence and Written Materials
Map (enclosed with this draft study)	

Methodology

As always, I found it advisable to interview or phone persons who know the area as a first step. If they could explain the geography of the site, relevant to the bounds of the graveyard and the location of graves, I brought them to the church site or met them there.

My next step was to check all deeds, wills, and other courthouse documents, plus the 1937 aerial photography, to see if these records jibed with findings of the people interviewed. Metes and bounds noted in deeds, and a plat of an adjacent tract, allowed me to pinpoint the church property.

At the same time, in the field I checked the area for depressions, fieldstones, and other indications on the ground relevant to the search. These field observations are noted on the accompanying map. And as I previously mentioned, so are the historic church property boundaries and other related data.

My main written and published sources, as well as persons interviewed are listed in the References section of this study.

A Helpful Hint to Reading This Draft Study

As I constantly refer to place names, buildings, gravesite locations--in total the geography of the area--it will be helpful to have the enclosed map handy when reading and digesting the report's contents.

Suggestions

As I mentioned, several persons whose forebears were interred in the graveyard expressed some embarrassment in that they had not done more to preserve the area, and were not as conversant about it as they might have been. All were very pleased that the graveyard would be preserved, and several commented that they hoped the stone house would be retained.

Their thoughts may be summed up in that they hoped the area would be cleaned up, the graveyard cleared of brush, and that the graveyard would be fenced in (the present wire fence was put up by Richard Byrne in the mid-1950's--previously there had been no fence around it within memory). They were referring to what is commonly called the LeFevre Graveyard, and not the entire church or graveyard site. In regard to this entire site they did not have any thoughts. Several persons said it would be nice to have an iron fence, traditional for what might be termed 'upper class' graveyards in the late-19th and early-20th centuries. Again, they were referring just to the LeFevre Graveyard, which measures about fifty by seventy-five feet.

My first recommendation is to rid the LeFevre Graveyard of all trees, and all close-by trees; these root systems damage gravesites. I would also clear the graveyard of all brush, but not the periwinkle, as that was planted on purpose to keep grass and weeds down; also, stock, which roamed freely among the stones, were not fond of periwinkle. Leave any stone or rock fragments in the graveyard where they are; they may have been part of a marker.

I would seed the remainder of the church lot with grass, allowing the periwinkle to expand. A basic pathway network, especially to the LeFevre Graveyard, and to the church site, would be appropriate. Stone or mulch might be used. I have noted a possible pathway network on the accompanying map.

While an iron fence might be appropriate for the LeFevre Graveyard, it would not be historically appropriate for the

entire church lot. If that lot were enclosed in the 18th century, a split-rail fence or similar rustic wood fence would have been used. That, prior to 1829, the lot was fenced, is implied by Peter Oatyer's will; it notes, "a black oak tree to which the gate to the Church lot hangs." Mr. Oatyer then owned the property. The gate probably would have been wood.

So, there's the option of fencing in the LeFevre section of the graveyard with an iron fence and the remainder with a split-rail or similar fence. Or, one could just have the latter style of fencing surrounding the entire church lot. As the LeFevre section was undoubtedly part of the original church graveyard, I'd recommend the latter approach.

Regarding trees outside of the LeFevre Graveyard, I would leave all those currently standing if not of the 'junk' variety. The tree line about thirty feet west of the LeFevre Graveyard can remain, if desired, and so can the trees some fifty to eighty feet north of the graveyard. At this time I especially recommend keeping the clump of three trees--one a sapling--standing just southeast of the downed metal corn crib. These trees mark the location of the old church.

If one were to add trees to the church lot, black oaks and white oaks are frequently mentioned in old deeds. The Eastern Red Cedar is the traditional area tree one finds in old graveyards, and one might use these as borders.

A marker denoting the history of the church site would, I'm sure, be appreciated, though no person I spoke with mentioned a marker. The best place for the marker would probably be at an entry from the recreation area, or in front (at the south of) the church site. Visitors should be allowed to park in the recreation-area lot, or there might be provisions for a few added parking places.

Only after careful pruning and cleaning up of the graveyard should grave markers be righted--some have fallen down. Foot stones hint at the correct locations of the head stones.

History of The Broad Run Church Property

On this parcel of land stood the first church, with its accompanying graveyard, built by the Anglican Parish known as Cameron. Eighteenth-century deeds call the building Broad Run Church or Broad Run Chapel, constructed sometime after the parish's founding in 1749, and October, 1752, when it is called "The new Chappell." The land was then owned by either William Sturman, granted 935 acres in 1728, or his son, Foxhall Sturman, who inherited the tract.

Except for one page of vestry minutes, Cameron Parish records are probably lost (Virginia Bishop William Meade could not locate them in the mid-1850's). No deed to the original church property has been recorded. Anglican church properties in this area were generally about two acres in size, and that acreage included the graveyard. The only document confirming that the church was Anglican is found in a 1767 chancery suit; in it is the page of vestry minutes, dated November 16, 1764. This page of levies notes that 800 pounds of tobacco were to be allotted "To John Lewis Clerk at Broad run," and 400 pounds of tobacco were to be allotted "To John Piles Sexton at Broad run."

The building was standing in 1766, for a May 4 deed to the property, from Kitchen and Ann Primm to John Pyles--our sexton--mentions "about one Acre Excepted out of this Grant where the Church stands." Mr. Pyles must have been saving monies from his tobacco sales, for he had bought 600 acres.

The building was also standing in November, 1779, for John Piles's six-plus-acre lease to Joseph Moxley begins "at a markt Persimon Bush on the east side of Broad Run Church about Twenty poles from the same." This lease includes the church and graveyard, but the "one acre Excepted . . . where the Church stands" clause, specified in the 1766 deed, is missing. The absence of this reservation clause indicates the church might

not have been used--at least by an 'official' Anglican Church. The country was then in the turmoils of revolution, and the status of the Anglican Church and its properties was then unclear. Seventeen eighty-two and 1797 deed transfers of the tract from which the church property was taken do not include a reservation clause and do not mention the church.

Two names related to the church became fixtures during this period: "Broad run Church road" (present Waxpool Road) first noted in 1766, and referred to in 1773 and thereafter as Church Road; and Church Spring, first referred to by that name in 1797. This is the spring at the springhouse south of the stone house. In 1811 the branch of Beaverdam Run (crossing Waxpool Road west of the church site) is named Church Spring Branch.

When I asked old-timers if they knew anything about the church, the standard reply was that they heard it was a Presbyterian Church. These replies link to the Rev. Amos Thompson, a noted Presbyterian minister, buying 372 acres "Commonly Called the broad Run old Church Tract" in 1803--a year before his death. Reverend Thompson, who founded Catoctin Presbyterian Church near Waterford in 1764, and Gum Spring Presbyterian Church at present Arcola in 1776, may have preached at Broad Run long before he bought the land. The only written record readily available noting that the church was Presbyterian is a handwritten note stating that Confederate veteran Samuel LeFevre was buried at the "Old Presbyterian Church." His gravestone stands in the LeFevre section of the graveyard.

The 1803 deed, and an 1801 deed of the same property to Jonah Thompson (relation to Amos Thompson not readily ascertained) and Richard Veitch, both note that the land includes "the Church yard which Contains One Acre and is reserved for that use." Inclusion of this clause, absent from the 1782 and 1797 deeds, suggests the church was being used. In 1811, however, when Peter Oatyer buys the 362-plus-acre "Broad run Church Tract" from commissioners settling Reverend Thompson's

estate, the reservation clause does not appear in the deed.

The lengthy and carefully prepared 1829 will of Peter Oatyer (the spelling changes) also omits the reservation clause. The will notes that to daughter Elizabeth Moffett he gives "about four or five acres of which is called the old church lot." And, as I previously mentioned, the boundaries of this acreage note "a black oak tree to which the gate to the Church lot hangs." To daughter Elizabeth he also gives "the right & privilege of getting out of the Spring called the old school house spring on the church lot, with the privilege & use of a waggon road to the same." The school house spring was the church spring, with the new name referring to a school house lot, noted in 1773 and 1779 deeds. This lot and the school house were south of present Waxpool Road, west of the stone house.

Yardley Taylor's 1853 Map of Loudoun County shows a building about where the church stood, and names its occupants "S. & J. Lefevre" (Samuel and John Lefever). Their gravestones are among the thirteen inscribed markers in the LeFevre section of the graveyard. None of the persons I spoke with recalled hearing of a house at that site, or that the family lived there. This house might have been the church, converted to a dwelling. By 1874, Samuel and John LeFevre were living at their new stone house across the road. Property-tax records might indicate what happened to the church or house. After 1853 there is no mention or notation of the church or graveyard in records or maps until 1986, when the graveyard appears on a survey of the future Broadlands property.

Summary of The History

The church and graveyard were in intermittent use from about 1750 until at least 1803, under auspices of the Anglican Church until the mid-1770's. It's not definitely known when

Presbyterians worshiped at Broad Run Church--possibly from the 1770's through the first decade of the 18th century. Assumptions aside, there was a building at the site in 1853, and there was no building at the site within anyone's memory. The last known interment in the graveyard was in 1911 (in the LeFevre lot), and the last known interment in the graveyard outside of the LeFevre lot was in 1905.

As to the size and shape of the church property, important to this study, we can only assume it was initially about two acres. The 1766 deed notes the size as about one acre, with the various reservation clauses through 1803 noting the size as one acre. Then, Peter Oatyer's 1829 will mentions the size as four or five acres, but I believe he was referring to the six-plus acres, minus the one-acre church lot, leased to Joseph Moxley in 1779. Of the possible shape, note the accompanying map.

The Graveyard

While there is no specific reference to an Anglican graveyard at the Broad Run Church, nearly all extant deeds to Anglican churches contain provisions for a graveyard. Also, the words "church yard" in 1801 and 1803 deeds could refer to a burying ground, as those words were often synonymous with graveyard. And, as persons remember burials in areas outside of the LeFevre plot, these burials of persons of community standing would not have been located outside of an established graveyard, especially in 1900 and 1905--the dates of the last known interments outside of the LeFevre plot.

Of interest, the purported locations of these last burials, and the locations of two interments of 1886 and 1897, are some 300 feet from each other, diagonally across the old barnyard (see the accompanying map). The LeFevre lot forms the right angle of a triangle shaped by the diagonal. Assuming that the churchyard north of present Waxpool Road--in just about the same location as the old Broad Run Church Road--was roughly a square (a plausible assumption)--the east side of the churchyard would coincide with the axis of the old dairy barn. This quadrilateral measures slightly more than an acre. The remainder of the churchyard might have included the spring--also a necessity for a public place--and thus would have been south of the road. As land about the spring is often miry, the higher land (by more than ten feet) and firmer soils north of the road would have been the choice land for a church and burial sites.

Most of the churchyard would be for projected graveyard use. The building, probably frame or log, would probably have measured some twenty-five by forty feet. The other main area to be kept clear of burials would have been an oak grove for outdoor meetings and services. Thus, at least three-quarters of the churchyard was slated for future gravesites.

In the 18th and early-19th centuries, before the general

advent of formal family burial plots, family burials were usually in the same area. Therefore, another family would choose a different location, not necessarily adjacent to an existing family's interment area. Thus today we have the scattered nature of known interments in what might be termed the 'old section' of the graveyard.

In the LeFevre section, logically kept up as that family lived and farmed the acreage--known as Hillside since the early-19th century--from the 1790's until 1915, there are thirteen marked stones, two other known burials, and two possible burials. There are several unmarked stones and depressed interment sites. Below is a list of those interred, some details about them (I have not checked wills, censuses, etc.), and the initials of my informant. For details see the References section of this study.

1) Jas. H. Bradshaw, b. Feb. 5, 1770; d. March 10, 1826.

The "70" and "26" are now broken off, with this fragment held for safekeeping by John D. Lewis of Mobil. This stone is at the extreme southwest of the plot, somewhat outside of it; therefore I marked it with a stake and yellow ribbon.

2) "I KNOW THAT MY REDEEMER LIVETH"--this inscription can be inferred by the surviving letters.

3) "Peter Oyvir [Oatyer]" b. 1751, d. May, 1834. The inscription faces west, as does stone 2). Other inscriptions face east. This stone is north of 2), which is north of 1). This section is the oldest part of the LeFevre section.

4) Samuel Lefevre, b. Aug. 15, 1828, d. Jan. 8, 1904. Son of Mary Etcher Lefever and William Lefever, Private in Loudoun Artillery, then Fauquier Artillery, prisoner-of-war. Bachelor. Unusual headstone with maltese cross; at top of cross "SOUTHERN CROSS OF HONOR"; in center of

cross "DEC. VINDICE 1861 1865"--a Latin inscription meaning 'in death, vindicated' (referring to The Confederacy) And at the bottom of the stone are the words: "None better have never or will / ever live than those who fought / for the South." (EC)

- 5) John Lefevre, b. Oct. 12, 1829; d. Aug. 1, 1903. Brother of Samuel Lefevre. John insisted on spelling his name "Lefever"; the stone cutter was not informed. (EC)
- 6) Mary E. Lefevre, b. May 18, 1835; d. Jan. 5, 1911. Wife of John Lefever. Her maiden name was Mary Elizabeth Houser. (EC)
- 7) Mary E. Havenner, b. Dec. 14, 1837; d. Aug. 15, 1852.
- 8) Mary E., wife of R. H. Havener, b. Jan. 4, 1843; d. Oct. 29, 1879.
- 9) Basil Havenner, b. Nov. 25, 1800; d. Jan. 12, 1855. Mrs. Cooke's Bible spells the name "Havener." (EC)
- 10) Rachel Havener, wife of Basil Havener, b. Oct. 20, 1811; d. March 11, 1890. Mrs. Cooke's Bible notes her maiden name, Rachel Lefever, daughter of William and Mary Etcher Lefever, and her death date as March 9, 1890. (EC)
- 11) Martha E. Alexander, b. March 19, 1850; d. Jan. 25, 1878. She was the daughter of Rachel and Basil Havener. Mr. Powell's notes have her middle initial as "H." (RP)
- 12) Joseph Arundell, b. Sept. 6, 1808; d. March 13, 1881. Mr. Arundell was postmaster of Farmwell (now Ashburn), 1867-1869. The accent is on the second syllable.

- 13) Honor Arundell, b. March 30, 1813; d. Feb. 13, 1872. The wife of Joseph Arundell and daughter of William and Mary Etcher Lefever. Mrs. Cooke's Bible spells the name "Honour" and gives her birth date as June 30, 1813. (EC)

Additional names appear on the large marker near the center of the LeFevre plat, erected ca. 1957. Estelle 'Esthe' Maffett Ellmore; her daughter, Goldie E. Maffett; and cousin Horace Raymond Wortman paid for the marker. They lived together near Murray's Ford. Mrs. Maffett researched the burials, all of which are in the Broad Run Church Graveyard, but not necessarily in the LeFevre section. Roger Powell now has Mrs. Maffett's notes. These additional names appear on the marker, which contains no birth or death dates.

- 1) John Maffett, b. June 19, 1771; d. Oct. 23, 1813. (ET)
- 2) Betsy Etcher, wife of John Maffett, b. Jan. 25, 1779; d. April 26, 1839. Her first name was Elizabeth. (ET)
- 3) Nellie Caylor. Her full name was Mary Eleanora Maffett Caylor, the daughter of Betsy and John Maffett. (ET)
- 4) James Caylor, the husband of Nellie Caylor.
- 5) William Lefever, b. Jan. 28, 1777; d. Jan. 8, 1850. (EC)
- 6) Mary Etcher Lefever, wife of William Lefever, b. Jan. 26, 1788; d. Jan. 25, 1832. (EC)
- 7) William Lefever, Jr., b. Nov. 30, 1816; d. Oct. 3, 1863. He was the son of William and Mary Etcher Lefever. (EC)
- 8) Elizabeth Houser, d. Jan. 5, 1911. Mrs. Cooke's Bible gives her full name as Mary Elizabeth. She was the wife of John

Lefever. (EC)

- 9) Rachel L. Wrenn, b. Sept. 9, 1869; d. March 20, 1892. Mrs. Cooke's Bible gives her middle initial as "E." She was the daughter of John and Mary Elizabeth Lefever. She married a Mr. Moulthrop (spelling?); a son was Larry Wrenn. (EC, RP)
- 10) Mary LeFevre, b. Nov. 6, 1861; d. March 3, 1886. Mrs. Cooke's Bible records he middle name as "Rosena." Mr. Powell's notes record her middle name as "Rosanna." She was the daughter of John and Mary Elizabeth Lefever. (EC, RP)
- 11) Annie L. Jenkins, b. June 1, 1864; d. Nov. 19, 1898. Mrs. Cooke's Bible gives he middle initial as "D." She was the daughter of John and Mary Elizabeth Lefever. (EC)
- 12) Mary Jane Jenkins, b. Nov. 30, 1888; d. July 11, 1910. She was the daughter of Annie L. Jenkins. (EC)
- 13) Edward Fling
- 14) Nora Fling, daughter of Edward Fling
- 15) Josephine Fling, daughter of Edward Fling
- 16) Sam Shryock
- 17) Betsy Maffett, wife of Sam Shryock. Her full name was Ailsey Elizabeth. She was the daughter of John and Elizabeth Etcher Maffett. Her first husband was a Mr. Mills. (ET)

To these names Roger Powell adds two burials cited in his notes:

- 1) John Peter Etcher, d. March 19, 1800. Drowned in a freshet at Murray's Ford, his body was not found until April 20. He was the son of John Peter Etcher and Mary Ann Dawson Etcher; both parents are buried in the Etcher Graveyard west of Murray's Ford.
- 2) Emily Havener Havener, d. May, 1868. In 1866 she married Joseph Richard Havener, a first cousin.

Mr. Powell also believes these two persons are buried in the LeFevre plat:

- 1) Mary 'Polly' Howser Arundell, b. Sept. 15, 1815. She married Frank Arundell sometime before 1848, when her son, John, was born
- 2) Christian Howser, b. 1809?; d. 1872. His wife was Rosanna LeFevre.

Mr. Powell's list of burials in the Broad Run Church Graveyard outside of the LeFevre lot:

- 1) Phillip Houser, b. June 9, 1769
- 2) Deliverance Houser, b. July 26, 1773. The sister of Phillip Houser.
- 3) Martha Houser Havenner, b. Jan. 15, 1797. The daughter of Phillip Houser.
- 4) Rebecca Houser Culison, b. Nov. 17, 1798. The daughter of Phillip Houser.

5) Catherine 'Caty' Howser, b. Dec. 8, 1809; d. 1898. The daughter of Phillip Houser. See the map for her approximate area of interment.

6) Clinton 'Clint' Hoskinson, b. Sept. 18, 1852?; d. 1905. He married Linnie Burch in 1885. See the map for his approximate area of interment.

Marian Caylor Eamich's Bible notes these two burials in the Broad Run Church Graveyard. She recalls the locations, and they jibe with two possible burial sites noted by John D. Lewis, Chief Land Surveyor of the Mobil Land Development (VA) Corporation.

1) Nettie Otley Caylor, b. 1883; d. 1886. She was the daughter of Priscilla LeFevre Caylor and John Alexander Caylor, builder of the Stone House.

2) Veara Eva Caylor, b. 1889; d. 1897. She was the daughter of Priscilla LeFevre Caylor and John Alexander Caylor.

Finally, Roger Powell believes that this person is buried in the Broad Run Church Graveyard:

1) John Ellmore, a Revolutionary War veteran, born in Fauquier County. He was wounded in the war.

In summary, there are 13 marked stones in the LeFevre section of the Broad Run Church Graveyard, and 18 or 19 unmarked interments in the LeFevre section. There are two known possible interments in the LeFevre section. In other areas of the graveyard there are eight known interments and one known possible interment.

It's impossible to ascertain the total number of burials in the Broad Run Church Graveyard, but if I were forced to guess

I would venture some 50 unknown burial sites. The vast majority of these sites would predate the years of close-by major church graveyards: Ryan Methodist, organized 1849; and Ashburn Presbyterian, organized 1876.

Today, it may be hard to believe that a farmer--in this instance Earl D. Smith--would ignore burials of a scant score of years. But there was less concern for such matters a generation or two back. Also, most graves were probably marked with fieldstones, possibly small and without inscriptions (half the population could read). There were no preservation groups concerned with graveyards. Indeed, not until the late-1980's did Virginia ask each county to inventory their graveyards; this research would be voluntary.

In past generations there was a strong belief that one could do with their land what they pleased, unmarked or ill-marked graves were no exceptions. I recall a Madison County old-timer who had pointed out several family graveyards to me before showing me his family's plot, seemingly a small one in the middle of his vegetable garden. As we talked I realized many of his forebears were in there, far more than the small size and few stones indicated. When I asked if the graveyard were once 'larger,' he replied:

"Well, I guess each year I planted a bit more, maybe hit a stone or two, and it got smaller."

He could see my facial muscles move and added,

"But I didn't disinter anybody."

Now he was talking about direct kinfolk.

When Earl D. Smith began farming the LeFevre's Hillside tract in 1916 he was undoubtedly of the same mind. Also, 'E. D.,' as he was called, was from Iowa, and his family had been lain to rest, and would be laid to rest, in Galva, not Hillside.

Roger Powell, who recalls the Hillside barnyard (the old churchyard) in 1914, before the Smiths came, remembers it as grown up in brush and briars to the east of the Le Fevre plot,

and as relatively clear and punctuated with frame outbuildings south and west of the LeFevre plot. Ruth Smith Braaten, E. D.'s daughter (b. 1918), remembers from her childhood a hog sty and fenced hog yard where the large dairy barn stood. These memories are verified by others who saw the property in the 1920's, and by the Department of Agriculture aerial photograph FG 117-169, flown April 30, 1937. Other than the LeFevre graveyard plot, clearly outlined by periwinkle and ground cover, I could not locate other burial sites from the photograph. No informant could recall any specific grave markers, down, evidently by the time Lee and Corbin Franklin began their tenancy.

The first remembered unearthing of a grave came in the late-1930's, when Lee Franklin, Mr. Smith's farm manager, dug up bones and a purported skull, possibly that of Mr. Hoskinson, when he put in an underground gas tank some thirty feet north of the garage (see map). The second remembrance dates from 1947, when Jim Hawes, Jim Munday, and others, laid footings for the dairy barn. They told Loudoun County Deputy Sheriff Roger Powell that pieces of fieldstone markers ended up in the concrete. They also found a skull, which E. D. mounted in the rear of his Pontiac. He asked Roger Powell if he would like to see it, but Rog refused; "I was afraid it was Aunt Caty," he told me.

Earl D. Smith had stopped living at Hillside in 1926, after his thirteen-year-old daughter, Dorothy, died of pneumonia that December 12. Devastated, the family spent the winter in Kissimmee, Florida, and then established residence in Arlington, where E. D., an expert mechanic and just about everything else, went into the plumbing business.

He tenanted out Hillside on shares, first to Theodore Schultz, from South Dakota, then by the mid-thirties to Lee Franklin and father Corbin Franklin. By the time Richard Byrne ran the dairy farm (1952-1963) no fieldstones remained in the barnyard. He came across no bones, and neither did tenant

dairy farmers Edgar Tillett (1963-1968) or Clayton Grant Polen (1968-1986). The latter three, all of whom I interviewed, spoke of accidental uncoverings of bones, related to them by Mr. Schultz and the Franklins.

By the time of the dairy barn building in 1947. thirty years of trampling by hogs had all but obliterated the known gravesites of 1889, 1897, and 1898.

Ruth Braaten, E. D.'s daughter, readily recalls how she and her sister would race their ponies to Ashburn School to get the best stables, but as to gravesites and markers she recalls nothing. Only the prevailing story that if you stood in the old machine shed at night, through the slats you could see a light coming from the LeFevre Graveyard.

The Stone House

Broad Run Church and Graveyard are geographically related to the Stone House, as the land on which it stands was probably part of the original church tract of ca. 1750, and as the Church Spring is now covered by the springhouse south of the house. Also, the builder of the house, John Alexander Caylor, buried two of his children in the churchyard (see p. 17).

Inscribed at the east of the window east of the front door are the letters: "J. A. CAYLOR / AU 1874." Both Betsy Carter and Marian Eamich, related to the Caylor, believe that Mr. Caylor laid the stone, and possibly did some or all of the hand-carved interior work. Mrs. Eamich told me that Mr. Carter did a lot of wood-carving, and learned carpentry as a bridge-builder on the Alexandria, Loudoun & Hampshire Railroad (later the Washington & Old Dominion) after the war. His dates are 1851-1921. He is buried at Ashburn Presbyterian Church.

John Lefever asked Mr. Caylor to build the house, and the family named it Hillside, the farm's name. Hillside is one of few old stone houses in Lower Loudoun, and its typical twin-chimneyed vernacular style harks back to the early- or mid-19th century. Samuel Conrad 'Con' LeFevre and family lived here before Earl D. Smith came in 1916, and the Smiths occupied the house until they left for Arlington in 1926. Earl D. Smith added the front porch (it replaced an older wooden porch) with its round, cement columns; the plumbing and its housing; and built the concrete springhouse--all shortly after 1916.

Elizabeth Cooke, Conrad LeFevre's daughter, recalls that her father told her there was a frame house at the site, and that this house burned. Yardley Taylor's 1853 Map of Loudoun County shows no house at the site.

The Schoolhouse Lot

I add this page because Margaret Lail Hopkins's book on Cameron Parish implies that Broad Run Church became a school. This is not true, for the school stood south of the Waxpool Road and west of the Stone House. It may have been built late in 1773, for that June 14, John Pyles and wife Jamima sold 150 perches (about .94 acre) to John Sinkler and John Davis, "Trustees for the Dutch settlement in the said Parish of Cameron" for 25 shillings. For boundaries, see the map.

'Dutch' was often synonymous for German (from 'Deutsch'), but it may have referred to Holland; Roger Powell believes the Housers, an early area family, came from Holland. Several other 18th-century area surnames have Teutonic rings. Elizabeth Cooke recalls that her father used to say the LeFevres were descended from 'Black Dutch,' referring to the Etcher (Oatyer) connections. She always thought that phrase to mean 'swarthy or dark-haired Germans.'

The School House Lot is mentioned in a 1779 deed, but I did not find further references to it. Peter Oatyer's 1829 will calls the Church Spring "old school house spring on the church lot." None of my informants recalled talk of a school at the site.

References

To Page 7

Cameron Parish takes its name from Thomas sixth Lord Fairfax, who was Baron of Cameron. He had recently moved to Belvoir, Fairfax County, of which the parish was a part. For further details on the parish see, Margaret Lail Hopkins, Cameron Parish in Colonial Virginia (privately printed, 1988).

For Mr. Sturman's grant see Northern Neck Grants B, 208.

Bishop Meade's two-volume Old Churches, Ministers and Families in Virginia, published in 1857, does not mention Broad Run Church.

The Chancery Suit is Lane & West vs. Evans Et Als, 1771, filed as M 2491.

The 1766 deed is in Loudoun County Deed Book E, 72.

The 1779 lease is in LCDB N(1), 56.

To Page 8

The 1782 and 1797 deeds are in N(2), 403; and Y, 37.

The 1766 deed noting "Broad run Church road" is in E, 72.

The first referral to Church Spring is in X, 320.

The first mention of "Church Spring branch" is in 2N, 75.

Reverend Thompson's deed is in 2E, 364.

John Divine of Leesburg has the notation of Samuel LeFEvre being buried at the "Old Presbyterian Church."

The 1801 deed is in 2B, 336. The individuals were trading as Thompson & Veitch; they were an Alexandria mercantile firm. At one time Jonah Thompson was Mayor of Alexandria. He was born in Loudoun County.

The 1811 deed is in 2N, 75.

To Page 9

Peter Oatyer's will is in Loudoun County Will Book V, 204.

For schoolhouse details see page 22.

The survey showing the graveyard is in 900, on the page following 1221.

To Page 10

Early Episcopal Convention journals, dating from 1785 to 1832, make no mention of a Broad Run Church. However, Cameron Parish rarely sent a representative to these conventions. See Journal of a Convention . . . Protestant Episcopal Church of Virginia (Richmond: Dixon and Holt, 1785 [to 1832, publishers and titles vary]).

To Page 11

Graveyard vs. Cemetery: The latter word, in its present connotation, comes into use during the late-19th century, perhaps because it was less graphic than 'graveyard.' As most burials in the Broad Run Churchyard predate that era, I have used the former designation.

Conrad LeFevre told Richard Byrne that the church stood at the site of the metal corn crib, now marked by three trees (see page 6). This location coincides with various metes and bounds I have drawn on the map.

Do not assume that the church faced the road; its long axis might have faced the road for the best light and to best winter winds.

To Page 12

The informants cited on the next few pages are: EC (for Elizabeth Cooke), ET (for Edgar Tillett), RP (for Roger Powell).

John Divine has additional war information regarding Samuel Lefevre.

To Page 13

Roger Powell's notes are mainly from notes of Catherine 'Caty' Howser, buried in the graveyard; and Estelle 'Esthe' Maffett Ellmore.

To Page 14

Inscriptions on the marker, in order and with proper wording, are noted in Hopkins, op. cit., p. 38. However, all the names are in capital letters, and she leaves out the words "IN MEMORY OF" at the top of each side. Her notation of "FRONT" is not on the marker, and means 'the east side.' Her notation "BACK" is not on the marker, and means 'the west side.' Also, "Arundel" should read "ARUNDELL" and the fifth line on the "BACK" side should read "AND DAUGHTERS"

To Page 17

Genealogist Craig Scott of Lovettsville adds the following information regarding Mr. Ellmore: He enlisted in a Virginia unit, and was seventy when he received a pension in 1818. He was still living in Loudoun County, ca. 1820. He also notes a John Elmore, Jr., a private in the Virginia Line, age eighty-six when he received a pension in 1818. He is still listed as living in 1835 (he would have been 103). Per phone conversation of May 10.

To Page 18

Earl Smith's widowed father, John Smith, bought the property from the LeFevres, then shortly sold it to his son--504 acres for \$11,000, an equitable price. See 8Z, 327.

To Page 19

Richard Byrne pointed out the location of the gas tank. Miss Hopkins adds the following comment in op. cit., p. 38: "Mrs. Tessie Penn Tillett . . . remembers that in the late 1930's the owner of the land adjacent to hers, Earl Smith, dug up almost all of the large graveyard and built the dairy barn where it stands today." The barn was built in 1947.

To Page 20

Again, for these burials see p. 17. Roger Powell did not exactly know the site of Aunt Caty's grave, but thought it somewhere by the north side of the dairy barn.

To Page 21

The house measures 20 by 45 feet, has a gabled roof, and is two stories with English basement at the south side. For some further architectural details and five photographs, see Virginia Historic Landmarks Commission survey form 53-991, compiled by David Edwards in October, 1982

Richard Byrne and Elizabeth Cooke have additional photographs of the house, and Ruth Braaten has a photograph taken before the additions of 1916. She told me she would try to make a copy of that photo and send it to me; I will forward the photograph to Mobil Land Development.

To Page 22

Miss Hopkins' reference to the schoolhouse is in op. cit., p. 41.

The 1773 deed is in I, 265.

Roger Powell brought up the true Dutch connection in a 1991 interview: In speaking of Philip? Howser, he says, "I don't know how far he was removed from the Netherlands." Seemy Dec. 13, 1991, interview with Mr. Powell, at the Thomas Balch Library.

References and Notes to Map

Annotations on the folded map enclosed with this report should, as mentioned before, be read in conjunction with the text. The map scale is 1" = 50 feet, meaning one inch on the map equals fifty feet on the ground. The map was prepared in 1993-1994, and shows the site before most of the farm structures were razed in the spring of 1995.

In trying to place the historic boundaries on the present landscape I used two points I thought were known, the church spring, which I believed was at or close to the 1916 springhouse; and the church building, pointed out by Richard Byrne, per Conrad LeFevre, to be at or close to the metal corn crib. However, the main spring has changed locations, and as the church might have been fifty feet long (an inch on the map), many of the boundaries came short of closure. The one written reference to the church building, in N(1), 56, 1797, notes a line to "a markt Persimmon Bush on the east side of Broad Run Church about Twenty poles [330 feet] from the same." This phrase, however, is not measured by compass points as are the other bounds. Thus we have approximations.

On the map the boundaries are referenced with deeds and dates; the bounds often disagree by two or three degrees, with the one constant bound the 1797-and-thereafter 165-foot boundary from the Church Spring to Church Spring Branch. As noted on the map, the earlier Church Spring (1797 and before) was at or close to the springhouse.

From the approximate (I'd say within ten feet) locations of the four gravesites noted on the map, the various deeds, and the lay of the land, I would say the original Broad Run Church lot coincided with the general barnyard boundaries, the LeFevre section being in the northwest corner. South of the historic Broad Run Church or Waxpool Road, the boundaries may have been a triangle, its apex at the Church Spring. This south area is of less concern as there are no graves in it.

I have marked the critical area north of the road with a red line and red border, and for safety's sake, would add a fifty-foot strip north of this border, marked by a dashed red line. Within this border I have marked a possible pathway system as mentioned in the Suggestions section of this study.

References to On-Site Visits and Phone Conversations

Ruth-Smith Braaten, 813-792-0825. Phone call, May 1

Richard Byrne, 955-1614. Visit to site, April 27; Phone calls, April 26, May 1

Betsy Caylor Carter, 327-4636. Two phone calls, April 25

→ Elizabeth LeFevre Cooke, 729-0211. Visit to site with her husband, John^w, April 26; Phone calls, April 25, 26
L Ashburn - Va. rd. Partlow Rd. Bickhouse on way

John E. Divine, 777-9580. Conversation, April 29; Phone Call, May 3

→ Marian Caylor Eamich, 729-0804. Phone call, April 23
(Mrs. Walton B) L Ashburn 20942 Ashburn Rd.

Thelma Hall, 729-0512. Phone call, April 24

Marty Hiatt, 822-5292. Phone call, April 30

Louisa Hutchison, 777-1332. Conversation, April 29; Phone calls, May 1, 2

John D. Lewis, 742-6400. Visit to site, May 4

Clayton Grant Polen, 729-2615. Phone calls, April 24, 27

Roger Powell, 822-5595. Visit to site, April 19; Phone calls, April 18, 20, 21, 24, 25, 27

Craig Scott, 822-5292. Phone call, May 10

→ Edgar Tillett⁽⁷⁰³⁾, 729-0512, Conversation, April 28; Phone call, April 27
Lina Waxpool

References to Correspondence and Written Materials

Barnett, Roy R., Vice-President, Loudoun Division, Van Metre Companies, to S. Fred Popkins, April 17, 1989. The crux of this letter states: "I envision the family burial plot to remain undisturbed during any land development activities, the burial plot to be delineated with some type of fencing, and the area to be cleared of any brush or undergrowth and seeded with a quality grass mixture. There after, depending on the desires of the family members, maintenance would be completed on an on going basis by family members or their representatives, or the family could contribute a mutually agreed upon one time amount to the Broadlands Homeowners Association and maintenance of the family plot would then be part of the overall community maintenance program."

I have a copy of the letter, and there is a copy in the Thomas Balch Library in the Hillside Cemetery file.

"Buried at Hillside." Provenance unknown, date ca. 1989. Names and dates taken from Elizabeth Cooke's Bible. Does not include birth date of Mary Jane Jenkins. All this information included in Graveyard section of this study.

I have a copy, and there is a copy in the Thomas Balch Library, Hillside Cemetery file.

Carter, Betsy C., letter to Donna Miner, Oct.9, 1989, noting members of Caylor, LeFevre families, and Peter Oatyer are interred in the Broad Run Church Graveyard. Again, all information included in this study.

I have a copy, and there is a copy in the Thomas Balch Library, Hillside Cemetery file.

"The Family Tree of Henry, Mary and Linna Settle Maffett." Scrapbook in possession of Edgar Tillett. Provides details on Maffett family and burials. All information included in this study.

Popkins, S. Fred, letter to Mr. Barnett of Van Metre (see 1st reference this page), March 19, 1990. He thanks Mr. Barnett for his prompt reply, then notes: "I photographed the cemetery last week. I will try to video tape the area this week, and if time permits, also do an archaeological grid of tombstone markers and stone locations." Mr. Popkins died in 1994, and I have been unable to reach his widow regarding the photographs and his projected task. Her number in Alexandria is 971-9550.

I have a copy of the letter, and there is a copy in the Thomas Balch Library, Hillside Cemetery file.

DRAFT

HISTORIC AMERICAN BUILDINGS SURVEY

LEFEVRE HOUSE

HABS No. VA-_____

Location: 43051 Waxpool Road (SR 625) between the unincorporated towns/villages of Waxpool and Ryan, Loudoun County, Virginia.

USGS Leesburg, VA - MD Quadrangle, Universal Transverse Mercator
Coordinates: 18.282120.4321490

Present Owner and Occupant: Broadlands Associates
11911 Freedom Drive, Suite 300,
Reston, VA, 22090.

Present Use: The building is currently vacant.

Significance: The LeFevre House is an unusual example of a stone I-House in the Northern Virginia area. It is a strong illustration of the diffusion of Pennsylvania German construction techniques into Virginia. The building is also an important remnant of the early history of the Waxpool/Ryan area, and the only resource in the area related to the ownership of the LeFevre family who were large landholders in the area and important in its development.

PART I. HISTORICAL INFORMATION

A. Physical History:

1. **Dates of erection:** Although the building's materials, design, and construction techniques would appear to indicate an earlier date, a date stone located to the right of the front door, indicates that the building was constructed in 1874. Loudoun County tax records confirm a major improvement on the parcel around this time and oral history accounts also suggest an 1874 construction date.
2. **Architect:** This is a traditional vernacular structure and is not identified with an architect. Based on the date stone on the building, it is likely that John Alexander Caylor is associated with the building, likely as the carpenter/builder. (See Section A 4, below)
3. **Original and subsequent owners:**

References to the Chain of Title to the parcel upon which the LeFevre house stands are in the Clerk of the Courts' Office, Leesburg, VA. The parcel is identified as Tax Map 78 Parcel 55.

DRAFT
LEFEVRE HOUSE
HABS No. VA-____ (Page 2)

- 3/22/1994 Deed, Van Metre At Goose Creek Partnership to Broadlands Associates
- 1/7/1986 Deed, Goose Creek Acres, Inc. to Van Metre at Goose Creek (Parcel 5 - 32.5 A)
- 5/3/1960 Deed, Brewster T. Cornwell to Goose Creek Acres Inc.
- 8/7/1959 Deed, Earl D. Smith to Brewster T. Cornwell (504 Acres)
- 4/17/1916 Deed, John Smith to Earl D. Smith (504 Acres)
- 3/9/1916 Deed, W.H. LeFever et al to John Smith (504 Acres)
- 1/26/1901 Deed, John & Samuel LeFever to W.H. LeFever et al (504 Acres)
- 2/2/1850 Bequest, William LeFevre to John & Samuel LeFever (504 Acres)

4. **Builder, contractor, suppliers:**

It appears that the carpenter/builder of the house was probably John Alexander Caylor.

Caylor was born on August 2, 1851 in Redkey, Indiana. Both of his parents, James William and Nancy Caylor, were Loudoun County natives who by 1870 had returned from Indiana to farm in Virginia. Although it is not clear what brought the Caylor family temporarily to Indiana, much of the originally German Caylor family resided in Jay County, Indiana. It is not known when John Caylor moved back to Virginia; however, in 1869 at the age of 18, he married Loudoun County resident Priscilla Ann LeFever, so it is likely that by that time he was already living in Virginia. The couple first appear in the 1880 census, residing in the Broad Run district of Loudoun County, Virginia. The couple had eight children, of which six, according to the census of 1900, survived. Their children included: a son Theodore, born in 1872; a daughter Ella, born in 1874; another daughter Cora, born in 1876; a son Marion, born in 1888; and another son Adolphus, born in 1892. All of their children were born in Virginia. According to census records, the Caylor family's daughter went on to become a nurse, and their son, Adolphus, became a mason. The Caylor family had modest capital; in 1874, the year John Caylor built the LeFevre house, County tax records show that he owned no stock and the aggregate value of his personal property was \$38. By the 1910 census he is listed as owning his own home.

Six years after the construction of the LeFevre house, census records indicate that John Caylor was working on the railroad. According to Caylor family sources (interview with Betsy [Caylor] Carter), Caylor's job with the Washington and Old Dominion Railroad involved the construction of bridges. The same family sources

also indicate that he was known for his woodworking skills. The census of 1900 lists him as a day laborer. By 1910, he is listed in the census as working for himself as a carpenter in a shop. Although it is clear that John Caylor had strong construction and carpentry skills, no information has been found specifically linking him to the design or construction of other houses or to stone construction in particular, and Caylor's role in the construction of the LeFevre house is confirmed only by the building's date stone which gives his name. Caylor died on October 5, 1921. His wife died twelve years later on July 1, 1933.

Based on the measured drawings of the Caylor House which accompany this written documentation, it is apparent that a skilled mason was involved in the construction of the building. The building is virtually square, level, and plumb and is without question the work of a craftsman who had completed other stone structures. It is possible that Caylor acquired stone masonry skills while working for the railroad, although there is no documentary evidence of this. Another strong possibility is that Caylor completed only the carpentry work on the house and the masonry was completed by an anonymous skilled mason. Whomever it was that was responsible for the building's stonework had ties to traditional german construction practices.

No specific information has been located concerning the source of materials used in the construction of the house. Certain of the fieldstone used to construct the house may have been previously used and according to one source, piles of stone could be found in the fields surrounding the house in the 1910s. (These were ground up and used in the concrete flooring of the dairy barns.) There are no stone outcroppings in the immediate vicinity of the house.

5. **Original plans and construction:**

No plans, archival information, or oral history about the actual construction of the building has been uncovered. The earliest known photographs of the structure date to the 1910s.

Based on the existence of extant exposed wood supports on the rear facade, the LeFevre house originally had a two-story back porch. Photographs and oral history sources confirm that the porch was removed prior to the 1910s. No photographs or archival documentation has been found that describe the appearance of the porch. The purpose of a wood ledger, running below the second-floor windows on the rear facade, is unclear, although it may be related to the back porch structure. The presence of a pent roof, a sharply pitched roof attached to the walls of the building to protect entrance doors from the rain, seems unlikely given the existence of a porch below it.

The existing front porch is not original to the building. Given the presence of a seemingly original door at the second-floor level of the front facade, it appears

likely that the house was originally constructed with a front porch -- the roof of which could be accessed from the second-floor door.

6. Alterations and additions:

Pre-1910s

A 18-by-9 foot addition with stone foundations, located on the east side of the building was likely added in the 1910s. The addition extends along half of the side facade and extends out 8 feet on the southwest corner of the building. Constructed as a wood shed, this structure originally came up only to the basement level with the flat roof used as an open porch. Given the rough construction techniques, the addition was definitely not constructed at the same time as the rest of the building. In addition, oral history sources and photographs tentatively indicate a 1910s date. The addition's enclosed porch, accessed from what is now the kitchen, was added in the 1950s.

Based on evidence supplied by the building fabric, it appears that the interior plan of the second story of the house, as well as some or all of the interior plaster and moldings may be related to a turn-of-the-century remodeling. The original interior partition walls in the building were 1-inch thick plank boards that have subsequently been plastered over. Most of the second floor interior walls, with the exception of walls around the stairs appear to date from this turn of the century alteration. Partitions were added at this time to produce three bedrooms and a bathroom. Although it is not clear what the original room configurations here were, given the traditional plan of two rooms on either side of the stairs, it is unlikely that there were originally as many partitions as currently exist.

The window casing and, potentially, other moldings may well date to this turn-of-the-century remodeling.

1916-1926

According to oral history accounts (interview with Ruth [Smith] Braaten), the current front porch, which features concrete pillars and a concrete floor, was added to the building during the years that the Smith family lived in the house (1916-1926). The porch originally also had a balustrade around its roof. Indoor plumbing was apparently added around 1916. Concrete was also added to at least part of the basement floor during this era.

Also during this period, a barrel-vaulted concrete cellar was built into the bank immediately adjacent to the house (with outside access only). Although this type of structure was a common feature of traditional German construction in Virginia, an oral history source (interview with Ruth [Smith] Braaten) confirms a later date

for this feature. During this period also, the existing springhouse was replaced with a concrete structure and expanded.

1926-1953

What was originally the parlor (first floor east side room) according to oral history sources (interview with Marie Burns) was converted to use as the kitchen while the house was being rented out by the Smith family. At this time walls were furred out to accommodate pipes and insulation.

1950s

A septic system was not added until the 1950s. Also, at that time also the spring behind the house was condemned, and the water supply for the house became a well located close to the barns across the street from the house. A portion of the concrete floor in the basement level, which replaced the original wood floor was also completed during the 1950s. The second floor/porch of the addition was added in the 1950s. Also during the 1950s, a wood floor, in the basement was replaced with a concrete floor.

B. Historical Context

According to a number of sources (see e.g., Hopkins, Cameron Parish), the parcel of land upon which the LeFevre house is located, known as Hillside, was a significant site in Loudoun County history. Based on deeds and other sources of information, it appears to have been the site of one of the first churches in what was to become Loudoun County. The church was apparently constructed in 1752 and was the first Anglican church built for the new Cameron Parish. It was generally referred to as the Broad Run Church. According to one source, the church was originally a Free Church and later became associated with the Presbyterian denomination. No information has been uncovered describing the appearance of the church, which apparently fell down around the turn of the century. Although the precise location of the church has not been determined, it is likely that it was located somewhat to the north of the LeFevre House. Plats indicating the location of the church show the road, which is now Waxpool Road basically stopping on either side of the church. It is likely, however, that the position of the road has changed over the years.

The land upon which the church was located was part of a parcel acquired by Peter Etcher (also spelled Oatyer) in 1811. Etcher, one of the major landowner in the area, purchased the land at a public sale in 1811. Etcher appears to have been the common ancestral root for many of the families who occupied land in the area in the 19th Century and specifically for the Hillside parcel. One of Etcher's daughters married a LeFevre, and it was through her that the Hillside land passed into the LeFevre family. Another of Etcher's daughters married a

DRAFT
LEFEVRE HOUSE
HABS No. VA-_____ (Page 6)

Caylor, providing another link between the LeFevre family -- who owned the land upon which the LeFevre House was built -- and the Caylor family -- a descendant of whom constructed the LeFevre home.

According to oral history sources (interview with Roger Powell), Etcher was born in Germany, and came to Loudoun County by way of Pennsylvania. Germans first came to Virginia in the early 18th century. The first group of settlers were miners and settled on the Rapidan River near the confluence of the Rappahannock (in a town known which came to be known as Germanna). The major influx of German settlers, however, like Etcher, came into Virginia by way of Pennsylvania in the middle of the 18th century. Many of the newer immigrants settled in the north part of the Shenandoah Valley around the towns of Strasburg and Woodstock. Around 1731, Germans from the Valley crossed the Blue Ridge and settled into what is now the northern part of Loudoun County, near the present town of Morrisonville.

The Waxpool/Ryan area of Loudoun County has historically had a strong German presence. By 1853, on the first map detailing landowners in Loudoun County (the Yardley Taylor Map), many of the names are of German origin.

The portion of the Etcher land that came down to the LeFevres was the site of a family home prior to 1853 (it appears on the Yardley Taylor map). No information exists concerning this first LeFevre home, which likely was demolished or fell down after the construction of the new stone house in 1874.

John LeFevre, who according to oral history sources (interview with Betty [LeFevre] Cooke) was the force behind constructing the house, was born in Loudoun County in 1829. He, like his father, farmed the land and appears to have raised stock, dairy cows, and grown hay and some orchard stock. He lived with -- and farmed the land in common with -- his brother Samuel, and all land and tax records record their holdings together. The brothers were moderately prosperous farmers. In 1873, the year before the house was constructed, they owned 6 horses valued at \$450, 15 cattle valued at \$150, 30 sheep valued at \$90, 18 hogs valued at \$30, 2 carriages or wagons, 15 farming implements, 1 clock, and gold/plate valued at \$10. In 1870, each of the brothers had real estate in the amount of \$3,000 and personal property in the amount of \$1,000. No information has been passed down about why the house was constructed when it was, but in 1874 -- with John having six children and one on the way -- the existing house may simply have been too small.

John Alexander Caylor, who appears to have been the designer/builder of the LeFevre family home was undoubtedly selected by the LeFevres because of his relationship to the family. He was most immediately related to John and Samuel LeFevre through his wife, who was their niece. Architecturally, the house that Caylor built for the LeFevres, is a blending of typical Virginia vernacular design

and German vernacular architectural traditions. The original plan for the house is that of an I-house, a vernacular house type found throughout the United States and particularly plentiful in Virginia. The basic plan of an I-house consists of a two-story, one-room-deep structure. The plan usually consists of equally sized rooms located on either side of a central hall/stair. Traditionally, the kitchens in I-houses were located either away from the house, in an ell or in the basement. On the exterior, I-houses are symmetrical in their fenestration. In all of these features, the LeFevre house seems strongly connected to local non-Germanic vernacular design.

Other features of the house, however, reflect more of a German influence. In this category are the use of log beams and stone (in particular the pattern of using uncoursed stonework on all sides of the house except the front), the presence of a date stone, and the siting of the house -- on a slope permitting direct access to the basement story.

The house remained in the LeFevre family until 1916, when it was sold to John Smith who purchased it for his son, Earl Smith. Smith was from Iowa, and he moved into the house and turned the farm into a modern dairy farm. He was responsible for much of the modernization to the structures at Hillside, including bringing electricity and indoor plumbing to the house. He was the first in the neighborhood to have many of these improvements and his house had the only radio in miles. The Smiths resided in the house for eight years until the family moved to Arlington, Virginia. Thereafter, the farm was operated by tenant farmers.

PART II. ARCHITECTURAL INFORMATION

A. General Statement:

- 1. Architectural character:** The LeFevre House is a two-story, five-bay stone I-house showing Pennsylvania German design influence. It has a central hall plan and two interior gable-end chimneys.
- 2. Condition of fabric:** The building is generally in good condition with the exception of certain exterior walls, parts of the foundation, and parts of the chimneys that need to be remortared. According to the measured drawings prepared to accompany this documentation, both of the chimneys are listing outward to some degree. In addition, as is common in houses of this date, there is a noticeable north/south deflection (curve) in the floors of the structure.

B. Description of Exterior:

1. **Overall dimensions:** The LeFevre House is a two-story rectangular building, approximately 22 feet wide by 44 feet long. Both the front (north) and rear (south) facade have five bays. The side facades are a single bay wide.
2. **Foundations:** The foundations of the building are field stone.
3. **Walls:** The building has structural stone exterior walls. The walls are two-foot thick at the first floor level. The stones are irregularly coursed on the front facade and uncoursed on all other facades. The stone work is laid up in sand cement.
4. **Structural systems, framing:** The building's stone walls provide bearing wall support. The floor framing at the first floor level is of logs. The second floor and attic floor supports are of timber. The roof has log rafters.
5. **Porches, stoops, balconies, bulkheads:** Presently, the building has a full-length non-original, one-story front porch with wood roof and concrete floor and columns. There is a non-original stoop leading to the side addition to the building which appears to be contemporaneous with the addition.
6. **Chimneys:** The building has two interior gable-end chimneys. They are of fieldstone construction. There are fireplace openings for each chimney on both the first and second floor (all are boarded up.) There is also a fireplace opening in the basement as well as a possible oven, which has been filled in. A number of the openings appear to have been sealed to permit use of a franklin stove.
7. **Openings:**
 - a. **Doorways and doors:** There are a total of five entrances to the building. On the front (north) facade, one entrance (the main entrance) is located in the central bay of the first floor. Another is located on the second level directly above the main entrance. On the rear (south facade), entrances are located at the second and fourth bays of the basement level and the center bay of the first floor level. All of the door openings except for those at the basement level of the rear facade are unusually long and narrow. This is, in part, to accommodate a glass transom above each door.

The main entrance to the building features transoms on both the exterior plane of the opening and at the inside of the wall above the door. The exterior transom has three panes. At the inner level of the wall, the entrance consists of a half-glass door with four inset panels below and a single window above. Above the door is a simple two-pane glass transom.

The entrance on the second floor consists of a similar door that opens out onto the porch. On the rear facade, the first floor door originally opened out onto a rear porch. Like the other entrances it features a glass transom. The rationale behind having twin openings at the basement level is not apparent. Clearly, this area of the house, incorporating as it did the kitchen area, was a much used area. One potential explanation is that the separate entrance may have been used as an entrance for non-family members.

- b. **Windows and shutters:** With the exception of the windows at the basement level and two small attic windows on either side of the chimney, windows throughout the LeFevre house are two-over-two double-hung sash. The basement windows are six-over-six double-hung sash. Windows have simple wood lintels and sills. The attic windows are small, fixed, two-pane windows.

8. **Roof:**

- a. **Shape, covering:** The building's gable roof is of standing seam metal construction.
- b. **Cornice, eaves:** A simple unornamented wood cornice runs along the cornice line of the entire building.
- c. **Dormers, cupolas, towers:** N/A

C. **Description of Interior:**

- 1. **Floor plans:** The LeFevre House retains the traditional plan of a vernacular I-house: central stair/hall, single pile plan, end chimneys. The second story has been partitioned to produce four rooms. The east side of the building has been divided laterally (i.e., with a wall parallel to the side walls) into two narrow bedrooms. The west side has been divided into one long room running the length of the side of the house, and a bathroom located behind the stairs in the rear of the house. Both the basement and attic of the building are basically open.
- 2. **Stairways:** The main stairs between the first and second floors are open and located in the center of the building. They are bracketed and of wood construction. Certain of the balusters have been replaced. The staircase to the attic is boxed.
- 3. **Flooring:** Floors are of three-inch wide wood boards. The floor in the basement and the front porch are concrete slab-on-grade. Certain floors have been covered with carpeting and the bathroom floor is tiled.

4. **Wall and ceiling finishes:** Interior walls are plaster-on-lathe. Non-original finishes have been added to certain walls. For instance, the first-floor wall below the main stair is covered with imitation wood paneling.
5. **Openings:**
 - a. **Doorways and doors:** Most interior doors are simple four-panel wood doors with long upper panels and short bottom panels. The door leading from the first floor to the basement is half-glass. A simple wood molding with flush corner blocks is used around the doors. As discussed above, these moldings may date to the possible turn-of-the-century remodeling.
 - b. **Windows:** The simple interior window trim may not be original to the building. As discussed above, these moldings may date to the possible turn-of-the-century remodeling of the house.
6. **Decorative features and trim:** Aside from the molding around doors and windows, the fireplace mantles, which have been temporarily removed from the building, are the main decorative features. These four mantles are of a simple design and are of wood (painted) construction. As discussed above, these moldings may date to the possible turn-of-the-century remodeling of the house.
7. **Hardware:** Certain of the building's interior doors retain their early and/or original enamel door knobs. Most other hardware is not original to the building.
8. **Mechanical equipment:**
 - a. **Heating, air conditioning, ventilation:** The building is presently heated by a single large coal-fired furnace located below the stairs in the basement added after 1916. There is no duct work to carry the heated air to other parts of the building. A metal grate in the living room permits the heated air to travel to these rooms. Originally the house was heated by fireplaces, which were later replaced with stoves.
 - b. **Lighting:** The lighting system, which was added around 1916, includes single bulb fixtures and numerous modern fixtures.
 - c. **Plumbing etc.:** The building receives its water from a well located across Waxpool Road. Until approximately the 1930s, water was supplied from a well located immediately behind the house (in the springhouse). Water is furnished to the kitchen on the first floor and the bathroom on the second floor. Running water was added to the building in the 1910s.
9. **Original furnishings:** No known original furnishings have been identified.

D. Site:

1. **General setting and orientation:** The LeFevre House faces north onto Waxpool Road. It is located in a largely rural area that features farms and woodland.
2. **Historic landscape design:** No information survives about the historic landscape design. It is unlikely that there was formal landscaping around the building; however, at least in the 1910s a garden plot was located to the west of the house.
3. **Outbuildings:** Outbuildings located immediately around the LeFevre house include a concrete cellar and a concrete barrel-vaulted springhouse, both of which date from after 1916. Oral history sources indicate the presence of a smokehouse (no longer extant) located immediately to the west of the LeFevre house.

PART III. SOURCES OF INFORMATION

- A. **Architectural drawings:** Aside from the measured drawings accompanying this documentation, there are no known drawings of the building. It is unlikely that any exist.
- B. **Historic Views:** Photographs of the site are known to exist in two locations. Three undated photographs (pre-1916, and likely turn-of-the-century) exist in the possession of Betty [LeFevre] Cooke (Ashburn, VA). These photographs show a small portion of the rear of the building. Photos in the possession of Ruth [Smith] Braaten (Bradenton, FL) reportedly show the front facade of the building around 1918.
- C. **Interviews:**
- Personal interview 2/14/1995 with Betty [LeFevre] Cooke. Mrs. Cooke is the granddaughter of John LeFevre. She lived in the house for approximately one year, around 1917.
- Telephone interviews 2/15/1995 and 2/16/1995 with Betsy [Caylor] Carter. Mrs. Caylor is a relative of the John Alexander Caylor.
- Telephone interview 2/16/1995 with Marie Burns. Mrs. Burns occupied the LeFevre house in the 1950s.
- Telephone interview 2/16/1995 with Ruth [Smith] Braaten. Mrs. Braaten is the daughter of Earle Smith and lived in the LeFevre house from 1918 to 1926.
- Telephone interview 2/16/1995 with Roger Powell. Mr. Powell is a local historian.
- Personal and telephone communications with Andrew Wenschel (architect responsible for the measured drawings accompanying this written documentation).

D. Bibliography

PRIMARY AND UNPUBLISHED SOURCES

Loudoun County Deed Books.
Loudoun County Tax/Land Books.
Index to Chancery Suits.
Thomas Balch Library, Vertical Files, Family Names Files, etc.

SECONDARY AND PUBLISHED SOURCES

Dabney, Virginius. Virginia: The New Dominion. Charlottesville: University of Virginia Press, 1971.

Glassie, Henry. Folk Housing in Middle Virginia. Knoxville: University of Tennessee Press, 1975.

Hopkins, Margaret Lail. Cameron Parish in Colonial Virginia. Privately Published, 1988. (Available at the Thomas Balch Library.)

Kindig, Joseph. Architecture in York County. York, PA: The Historical Society of York County, ND.

Long, Amos. "The Pennsylvania German Family Farm." Publication of the Pennsylvania German Society. Breiningsville, PA, 1972.

Scheel, Eugene M. "Five Forks' Grew from Plantation." Loudoun Times-Mirror, ND. (Available at the Thomas Balch Library.)

Scheel, Eugene M. "Church Nurtured Waxpool Community." Loudoun Times-Mirror, ND. (Available at the Thomas Balch Library.)

Wayland, John W. The German Element in the Shenandoah Valley. Charlottesville: Michie Co., 1907.

Williams, Harrison. Legends of Loudoun. Richmond: Garrett and Massie Inc., 1938.

Wust, Klaus. The Virginia Germans. Charlottesville: University of Virginia Press, 1964.

MAPS AND PHOTOGRAPHS

Hoffman, J. Paul and S. Howell Broom. Map of Loudoun County Virginia and Jefferson, West Virginia . . . 1864.

Smith, William P., and A.S. Barrows. Map of Facquier and Loudoun Counties. 186_.

Yardley Taylor. Map Of Loudoun County. 1853.

E. Likely sources not yet investigated:

Family photographs in the possession of Ruth [Smith] Braaten (Bradenton, FL) of the LeFevre House were not accessible at the time this documentation was prepared.

F. Supplemental material: N/A

PART IV. PROJECT INFORMATION

The preparation of Historic American Building Survey (HABS) documentation on the LeFevre House was commissioned by Broadlands Associates of Reston, Virginia, in February 1995.

Prepared by: Carol Hooper, Architectural Historian, and Judith Helm
Robinson, Principal

Affiliation: Robinson & Associates, Washington, D.C.

Date: February 1995

HISTORIC AMERICAN BUILDINGS SURVEY

INDEX TO PHOTOGRAPHS

LeFevre House
43051 Waxpool Rd.
Loudoun County
Virginia

HABS NO. VA-____

Bill Lebovich, photographer, February 1995

- VA- -1 Distant view from Waxpool Rd., looking west at north (front) and east sides.
- VA- -2 Closer view of north and east sides.
- VA- -3 Nearly straight-on view of north and east sides.
- VA- -4 Detail, north side, column and front door.
- VA- -5 Detail, east end of 2nd story on north side and gable on east side.
- VA- -6 East and south sides.
- VA- -7 Detail, east end of south side.
- VA- -8 Detail, west end of south side.
- VA- -9 South and west sides.
- VA- -10 Detail, gable on west side.
- VA- -11 West and north sides.
- VA- -12 Root Cellar, south of house, west end.
- VA- -13 INTERIOR, basement, west room, looking west.
- VA- -14 INTERIOR, 1st floor, enclosed porch off kitchen, looking south.

**INDEX TO PHOTOGRAPHS
LEFEVRE HOUSE
HABS No. VA-__ Page 2**

- VA- -15 INTERIOR, 1st floor, kitchen, wall behind mantel exposed and mantel on floor, looking east.
- VA- -16 INTERIOR, 1st floor, hall, looking east at stairs. Doorway at left goes to basement, doorway at right goes to kitchen.
- VA- -17 INTERIOR, 1st floor, hall, looking south at back door.
- VA- -18 INTERIOR, 1st floor, west room, mantel propped against wall, looking west.
- VA- -19 INTERIOR, 2nd floor, east room, mantel propped against wall, looking east.
- VA- -20 INTERIOR, 2nd floor, west room, looking west. Underside of stairs to attic at top right of photograph.
- VA- -21 INTERIOR, attic, west room, looking west.

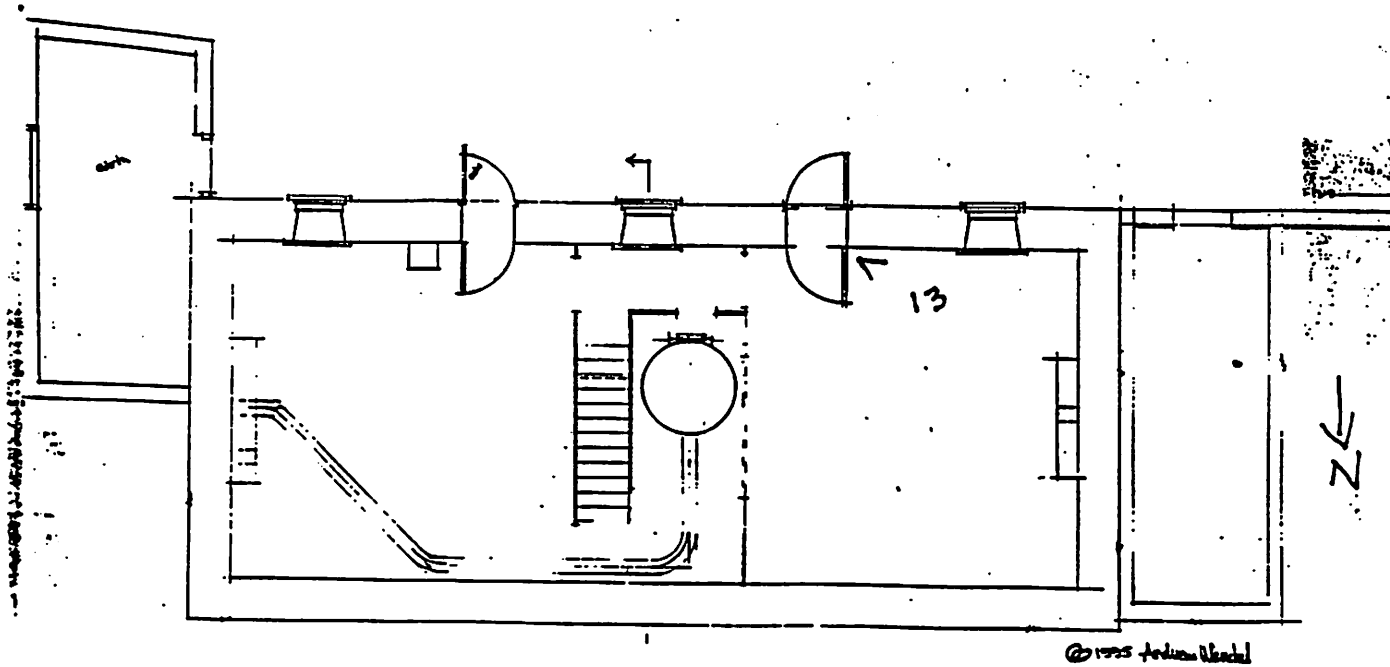

© 1925 Arthur Wood

BASEMENT

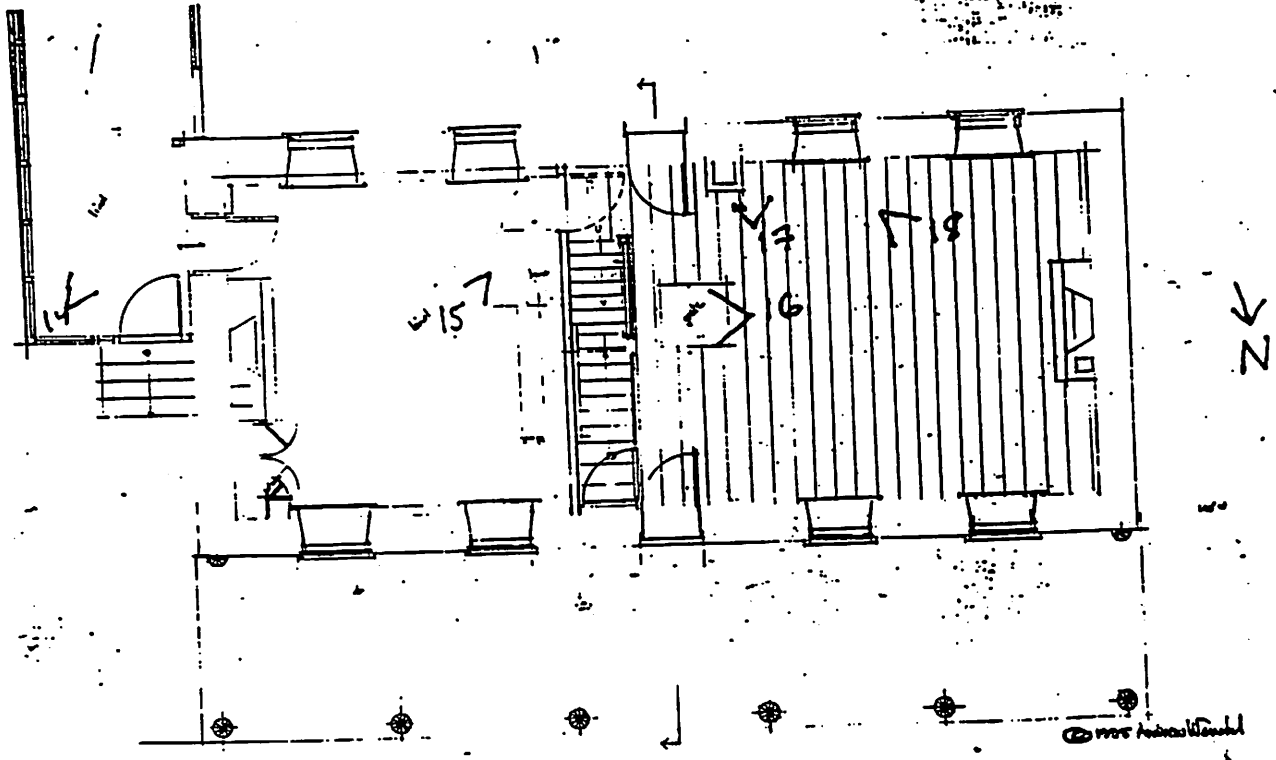

FIRST FLOOR

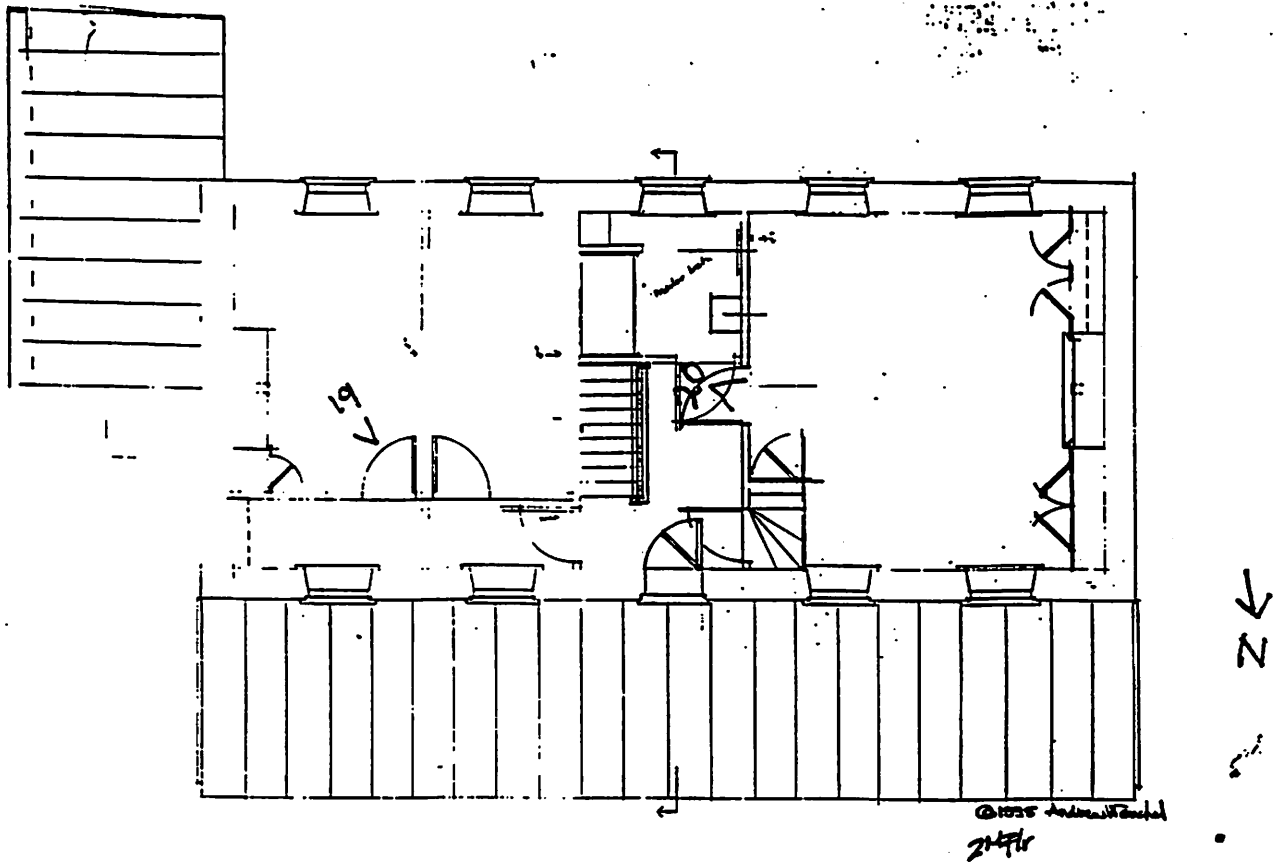

SECOND FLOOR

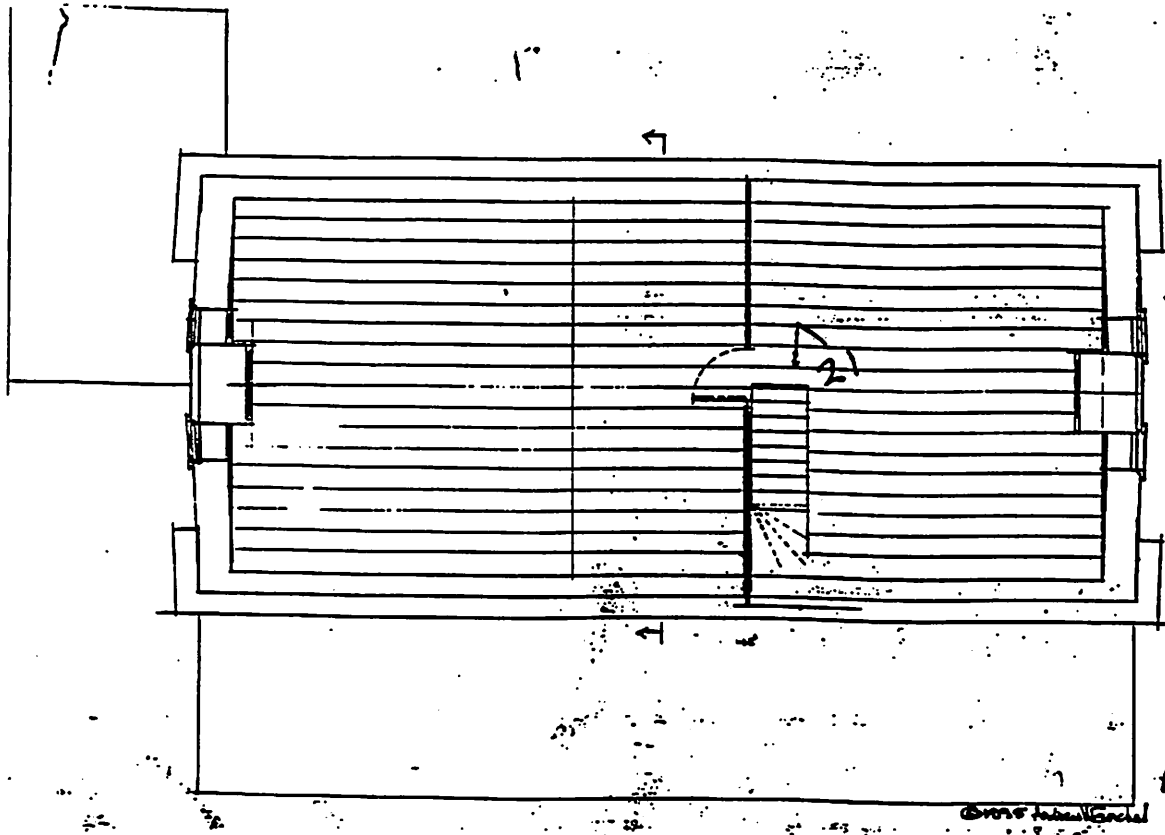

ATTIC

PHOTOGRAPHIC KEY
LEFEVRE HOUSE
HABS NO. VA-___ (Page 7)

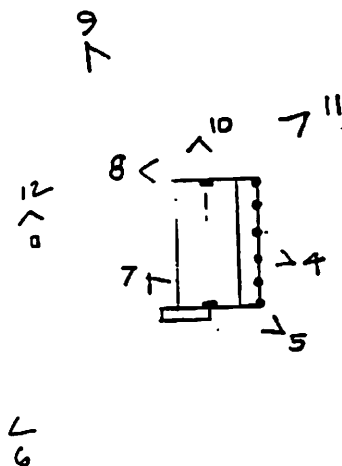

→ 3

→ 2

